

THE MODULAR TANK

NTG'S LATEST INNOVATION

SYSTEM SUMMARY

- Underground And Above Ground Installation
- Minimum Capacity Starting At 7,000 Liters
- Unlimited Capacity With Its Multi-Stage Assembly
- Guaranteed Polyethylene Quality And Strength

TECHNICAL DESCRIPTION

Type	Capacity liters	Length mm	Diameter mm
1 Module	7 000	2 636	2 100
2 Modules	10 000	3 636	2 100
3 Modules	13 000	4 636	2 100
4 Modules	16 000	5 636	2 100
5 Modules	20 000	6 636	2 100
6 Modules	23 000	7 636	2 100
7 Modules	26 000	8 636	2 100
8 Modules	29 000	9 636	2 100
9 Modules	32 000	10 636	2 100
10 Modules	35 000	11 636	2 100

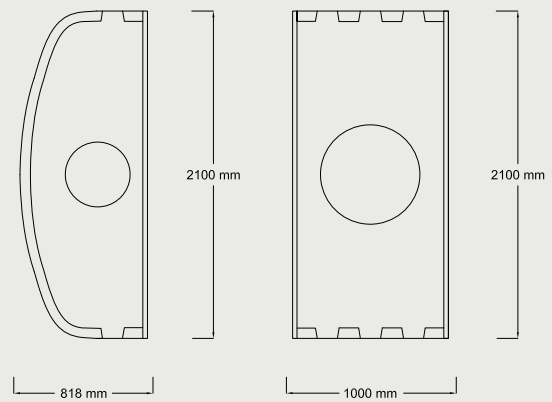



Nassar Techno Group

Mazraat Yachouh – Industrial Area

P.O Box 94 Bikfaya – Lebanon

T. +961 4 925000 **Fax** +961 4 925500

ntg@nassar-group.com

www.nassar-group.com